

CONTINUITY & RESILIENCE TODAY

BUSINESS CONTINUITY MANAGEMENT
PROFESSIONAL DEVELOPMENT EVENTS

ONTARIO DEMCON

DISASTER AND EMERGENCY
MANAGEMENT CONFERENCE

THE WORLD CONFERENCE ON DISASTER MANAGEMENT PRESENTS
34 YEARS OF RESILIENCE & EMERGENCY MANAGEMENT

OCTOBER 28-29, 2026 | INTERNATIONAL CENTRE | TORONTO



**SPONSORSHIP
PROSPECTUS**

CRTDEMCON.ca

OUR MISSION

THE CONFERENCE NAME MAY HAVE CHANGED FROM THE PRESTIGIOUS WORLD CONFERENCE ON DISASTER MANAGEMENT, BUT THE MISSION REMAINS THE SAME...

The Ontario Disaster & Emergency Management Conference (DEMCON)

features senior emergency managers from across North America telling their disaster management stories. With an emphasis on the practical, DEMCON provides a variety of session types that focus on lessons learned, new initiatives and best practices.

Continuity & Resilience Today (CRT) is Canada's premier business continuity management event, providing global perspectives on current and emerging issues for continuity and resilience managers. Practical and collaborative, CRT is an environment of shared lessons learned, networking, and professional development to strengthen resilience.

CONTINUITY & RESILIENCE TODAY

is planned by RIE and Preparing for the Unexpected



Resilience Information Exchange-Toronto chapter (RIE)

A non-profit association of professionals dedicated to the exchange of information on operational resilience and all aspects of planning for and responding to a disruption to normal operations.



Preparing for the Unexpected

A podcast with host Alex Fullick, *Preparing for the Unexpected* is about how people, organizations and communities plan, prepare for, respond to, and overcome sudden unplanned adverse events. Guests include thought leaders, disaster psychologists, researchers and academics, authors, and business continuity and resilience professionals. The podcast can be viewed daily on the Preparing for the Unexpected YouTube channel and on streaming services such as Spotify, GoogleTV, Roku, Apple, and Amazon. You can also watch it live every Thursday at 1:00pm ET on World Broadcast Network TV.

Promote your global brand, products and services at **CRT/DEMCON!**



ONTARIO DISASTER & EMERGENCY MANAGEMENT CONFERENCE

The education program for the Ontario Disaster & Emergency Management Conference is planned and developed in collaboration with:



Canadian Red Cross - The mission of the Canadian Red Cross is to improve the lives of vulnerable people by mobilizing the power of humanity in Canada and around the world.



Cifal-York is part of UNITAR's global network of training centers for knowledge-sharing, training, and capacity-building for leaders, local authorities, and civil society that includes Disaster Risk, Emergency Management and Humanitarian Actions.



Disaster and Emergency Management Student's Association (DEMSA) is for Master level students at York University. The primary aim of DEMSA is to enrich the lives and educational experience of our affiliated students (and the broader community) through social, professional, and academic programs.



Emergency Preparedness in Canada (EPIC) - Podcast delivers current, relevant, and Canadian educational content to share our passion for emergency management and disaster science. We interview leading experts in the field, review emerging and landmark publications, and debate important disaster issues.



International Association of Emergency Managers (IAEM) is a non-profit organization representing 4,000+ emergency management professionals for local communities, state/provincial and federal/national disaster officials, private sector and non-governmental organizations.



Since 1980, communities have counted on **Ministry of Emergency Preparedness and Response (MEPR)** when they needed us most. In fact, we are on the job well before an emergency occurs. Prevention and preparedness are key pillars of MEPR's mandate. When the unthinkable happens, MEPR is there to support community response and coordinate provincial activities as required.



Ontario Municipal Social Services Association (OMSSA) is a non-profit association that supports, connects, and advocates for our members across Ontario. We help them to achieve their collective mission of delivering the best human services outcomes for Ontario's communities.

SUPPORTED BY



BlueLine
Canada's only independent law enforcement magazine



Canadian Journal of Emergency Management
An open access online journal that publishes papers written by and for the Canadian emergency management community.



Canadian Security
The leading source in Canada for security directors, life safety managers, property managers, cyber-security managers and loss prevention professionals.



Emergency Manager
The official publication of IAEM Canada, EMLCanada, United Nations ARISE Canada, and DEMCON. Published twice per year in print and digital formats by The Davis Media Company Inc., it serves as Canada's national magazine for emergency management professionals.



FireFighting in Canada
To share news and developments in the industry and provide analysis and commentary on significant happenings in the fire service.

THE BENEFITS OF SPONSORSHIP

ALL PACKAGES include Website and Print listings and your Corporate Logo splashed on 40+ e-blasts to our database of 4,200 qualified Emergency Management & Business Continuity professionals.

TURNKEY EXHIBIT

Exhibits are table-top and each receives a 6' draped table, 2 chairs and electrical from Conference Management for super easy and fast set-up/tear down. The exhibit area is fully carpeted. 8'x 8' pop-ups OR roll up banners are permitted in your display. Each exhibit is 10' frontage x 5' depth.

PARTICIPATING SPONSOR - \$1,700

The budget friendly option that gets your Rep full access to the conference to network with 400+ delegates, PLUS corporate promotion to our database of 4,200 professionals (exhibit space NOT included).

NOT-FOR-PROFIT SPECIAL - \$1,800

Non-profit Associations are welcomed at 50% off the BRONZE level that includes one rep and turnkey exhibit package. Please note the custom e-blast and social media posts are not included.

Charity organizations - \$500

BRONZE - \$3,675

The base exhibit package that includes one Rep and a 1/2 page (shared) E-blast promoting your product to our database of 4,200 qualified EM/BC professionals.

SILVER - \$5,500

Includes TWO Reps, an exclusive FULL page E-blast promoting your product, a Delegate Bag Insert and a half-page Advertisement in the printed Directory.

GOLD - \$7,500

Includes THREE Reps, exclusive E-blast, Bag Insert and a FULL page Advertisement in the printed Directory. Add the ever popular 45-minute Presentation time slot for YOUR Speaker/Topic, a Seat Drop and FOUR Social Media Posts.

PLATINUM - \$10,000

Stand out from the rest with a DOUBLE BOOTH! Also includes FOUR Reps, exclusive E-blast, Bag Insert and a DOUBLE-PAGE spread Advertisement in the printed Directory. Additionally, a 45-minute presentation time slot, four Social Media Posts, TWO Seat Drops and a LIVE Podium Commercial.

OUTDOOR EXHIBIT AREA - \$150/SPACE

For vehicles, trailers and large scale equipment demos. Located steps from the lobby entrance means that all delegates see the exhibits upon arrival. Exhibit space is \$150/space (8' x 15')

CUSTOMIZE!

Packages are flexible. You can trade out any benefit to add in a different benefit of equal value – or simply add any benefit from the A La Carte menu to fully customize your sponsorship that meets your needs.

OUR DATABASE

Consists of **4,200 qualified** emergency management and business continuity professionals

Emergency Management

(includes First Responders with EM responsibilities)

Business Continuity

(includes Risk Management professionals)

SOCIAL MEDIA

6,000 followers

DEMCON and CRT have their own distinct social media platforms consisting of X, Facebook, Instagram and LinkedIn. Each sponsor receives one customized post promoting their participation to each platform = 8 individual posts, (GOLD & PLATINUM = 16 posts).

**REACH THE BUYERS YOU WANT TO SEE OVER 2-DAYS
SAVE MONEY, TIME AND EFFORT BY EXHIBITING AT CRT/DEMCON**

CALL TODAY TO DISCUSS YOUR SPONSORSHIP OPTIONS!

Dan Joyce Tel: 705-328-5323 (9-5 ET) | Email: danj@jjexpos.ca

SPONSORSHIP OPPORTUNITIES

PRODUCT	PLATINUM	GOLD	SILVER	BRONZE	PARTICIPATING
Company representatives	4	3	2	1	1
Display table (incl. chairs + electrical)	2	1	1	1	N/A
Dedicated pre-conference e-blast (4,200 records)	2	1	1	1 (shared)	N/A
Social media posts (6,000 followers)	16	16	8	8	N/A
40+ Content e-blasts w/logo	●	●	●	●	●
Onsite signage (corporate logo)	●	●	●	●	●
Printed directory listing	●	●	●	●	●
Website listing	●	●	●	●	●
Delegate bag insert	1	1	1		
Print directory advertising	2 pages	1 page	½ page		
50 minute presentation	1	1			
Seat Drop	2	1			
Live commercial from podium	1				
Cost of Sponsorship	\$10,000	\$7,500	\$5,500	\$3,675	\$1,700

A LA CARTE SPONSORSHIP OPTIONS

PRODUCT	COST
Seat drop	\$250
Live podium commercial	\$300
Delegate bag insert	\$350
Social media posts	\$500
Additional staff/ reps	\$500
½ page ad	\$500
Full page ad	\$750
50 minute presentation	\$1,500
Additional half-booth (5')	\$800
Additional full booth (10')	\$1,500
Dedicated e-blast	\$1,500
Outdoor Exhibit Area	\$150/space

EXCLUSIVE SPONSORSHIP OPTIONS*

PRODUCT	COST
Registration Portal	\$500
Lanyards	\$2,000
Conference bag exclusive (Conference bag co-sponsorship \$1,500)	\$3,000
Note pad and pen combo	\$3,500
Food Break sponsorship	call for quotation

*Limited on a first come, first serve basis
Exclusivity = Premium Brand Awareness!

Sponsor opportunities can be customized to suit your individual needs.

Please refer to the *A La Carte* and *Exclusive* Sponsor options



AGGREGATE DATA from 2018-2025 ANNUAL EVENTS

CONTINUITY & RESILIENCE TODAY
CANADIAN CONTINUITY CONFERENCE

ONTARIO DEMCON
DISASTER AND EMERGENCY MANAGEMENT CONFERENCE

ANNUAL ATTENDANCE
100 Business Continuity Professionals

ANNUAL ATTENDANCE
300 Emergency Management Professionals

BY INDUSTRY

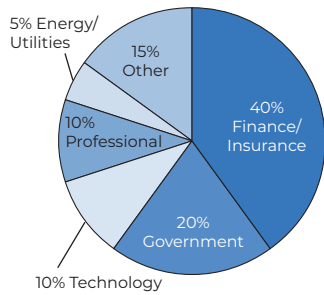

YEARS OF EXPERIENCE

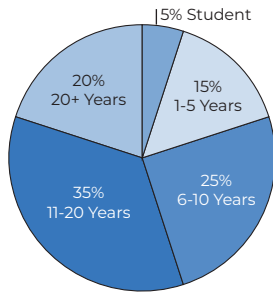

BY INDUSTRY

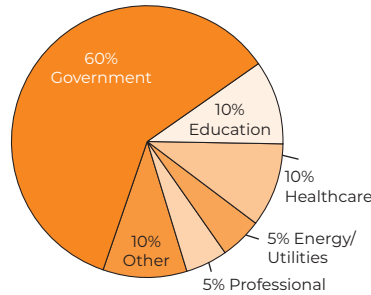

YEARS OF EXPERIENCE

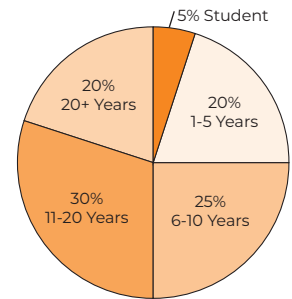

ROLE IN PURCHASING

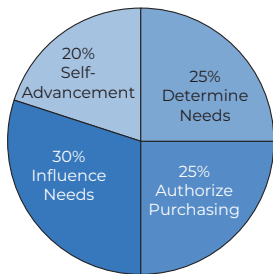

GEOGRAPHIC

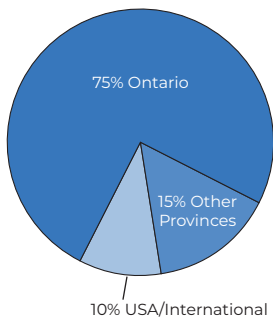

ROLE IN PURCHASING

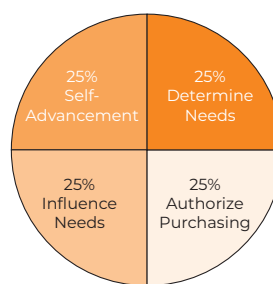

GEOGRAPHIC

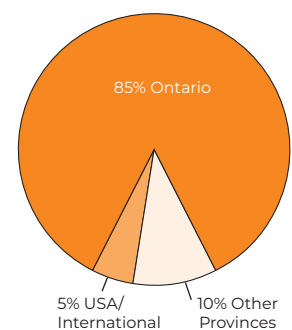

CONFERENCE BREAK SCHEDULE

TWO Programs with ONE exhibit! Emergency Managers and Business Continuity professionals attend separate programs. This allows staggered break times for each audience as shown below = **8 Hours of Break Time Over 2-Days!**

DAY 1	
Move-In	7:30am – 9:30am
Exhibits Open	9:45am
Mid-Morning Break 1	10:00am – 10:40am
Mid-Morning Break 2	10:40am – 11:30am
Lunch 1	11:35am – 12:25pm
Lunch 2	12:30pm – 1:20pm
Mid-Afternoon Break 1	2:20pm – 3:10pm
Mid-Afternoon Break 2	3:15pm – 4:00pm
Afternoon Reception	5:00pm – 6:00pm

DAY 2	
Exhibits Open	9:15am
Mid-Morning Break 1	9:30am – 10:00am
Mid-Morning Break 2	10:00am – 10:40am
Lunch 1	11:45am – 12:30pm
Lunch 2	12:30pm – 1:20pm
Mid-Afternoon Break	2:15pm – 2:45pm*
Move-Out	2:45pm

* Be sure to run a prize draw at your display table. Conference Management will announce your prize winner on Day 2 at 2:15pm.

Excellent conference. Well-paced, highly professional environment with variety of topics and speakers.
 – Laura Oke, District of Muskoka

CRT/DEMCON facilitated an excellent platform for networking, bringing together professionals from diverse fields to foster valuable connections and collaboration
 – Maja Ristic
 Ontario Power Generation

Still the best BCM/EM conference in Canada!
 – Graeme Jannaway, DRI Canada

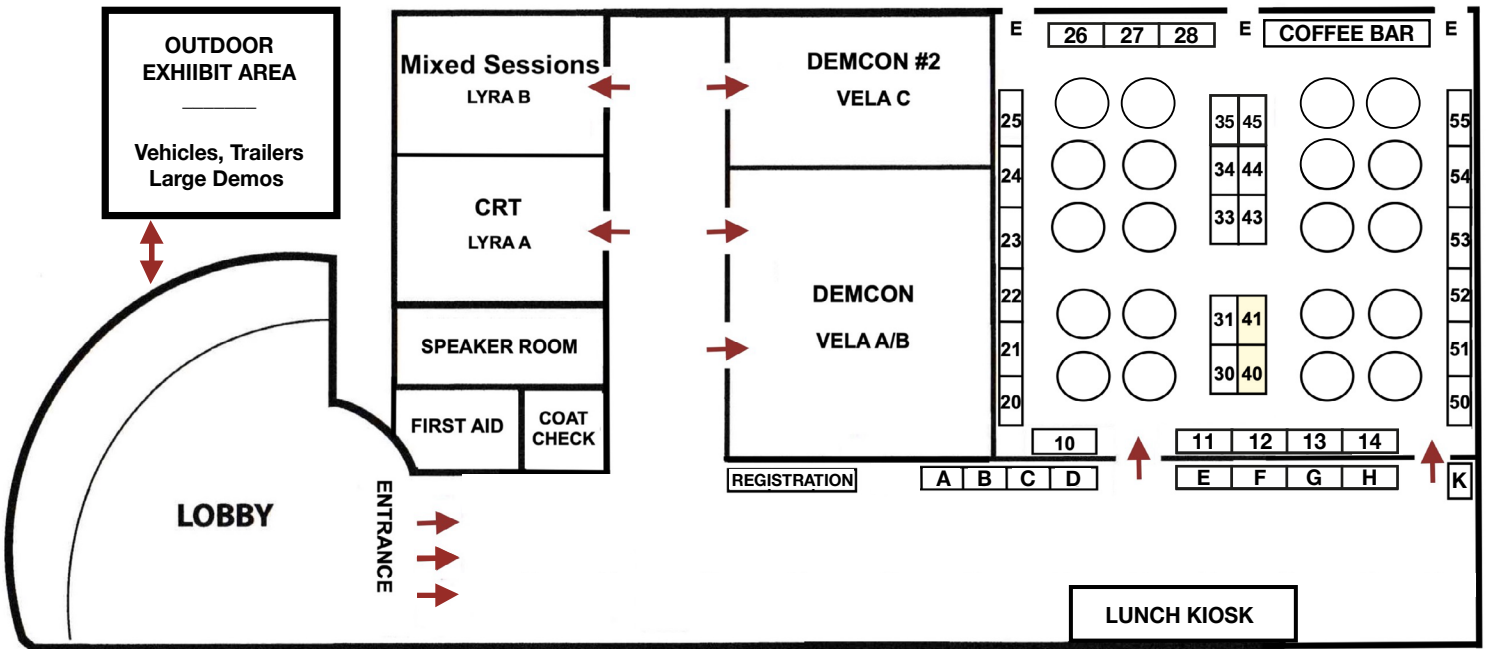

CONFERENCE CENTRE • INTERNATIONAL CENTRE • TORONTO

It was the best time I have experienced at a conference for a long, long time!
 – Regina Phelps
 EMS Solutions Inc.

The speakers were top notch! Very well organized and thoughtfully planned. Would attend again!
 – Geraldine Morrison, Region of Durham

Once again CRT/DEMCON proved to be of great value! Interesting, well-presented topics, excellent networking opportunities, relevant vendors, overall a great time!
 – Sherry Wright, City of Brampton

DEMCON

Call to discuss how we can best build your customized sponsorship!

Dan Joyce

Mobile Tel: 705-328-5323 (9-5 ET)

Email: danj@jjexpos.ca

produced by:

J&J EXPOSITIONS INC

P.O. Box 282, Lindsay, ON K9V 4S1



CRTDEMCON.ca